

ROADKIT



The new Era Gate accessories, with a minimal, modern and discreet design, renovate Nice kits' style and performance.

Discover the complete range at page 184



For sliding gates weighing up to 400 kg.

Practical: built-in control unit, can be connected by means of a simple connector and can be housed directly inside the motor; incorporated radio card, compatible with the Nice Flo and Smilo systems: 150 transmitters can be entered!

Advanced: the speed, strength and pause can all be adjusted.

Intelligent: thanks to the obstacle detection system and automatic programming of the working times. Self-diagnosis by means of a flashing light.

Practical: the control unit and PS124 buffer battery (optional) can be connected by means of a simple connector and can be housed directly inside the motor.

TECHNICAL SPECIFICATIONS

CODE	RD400
ELECTRICAL DATA	
POWER SUPPLY (Vac 50/60 Hz)	230
ABSORPTION (A)	1.1
POWER (W)	210
PERFORMANCE DATA	
SPEED (m/s)	0.25
FORCE (N)	400
WORK CYCLE (CYCLES/HOUR)	20
DIMENSIONAL AND GENERAL DATA	
PROTECTION LEVEL (IP)	44
WORKING TEMP. (°C MIN/MAX)	-20 ÷ +50
DIMENSIONS (mm)	330x195x277 h
WEIGHT (kg)	8

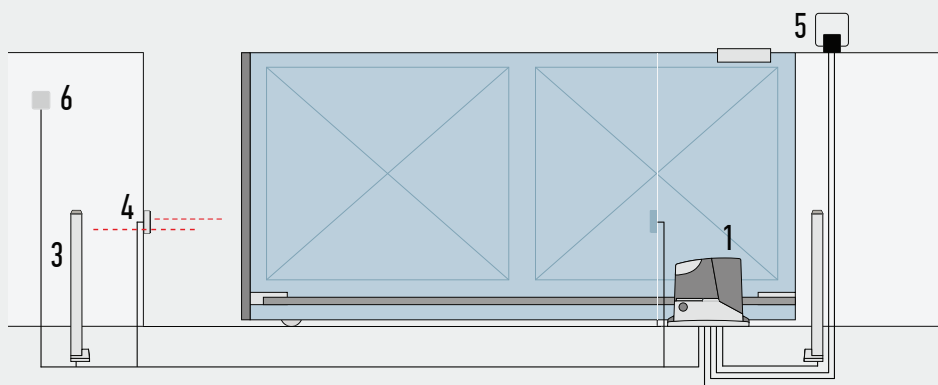
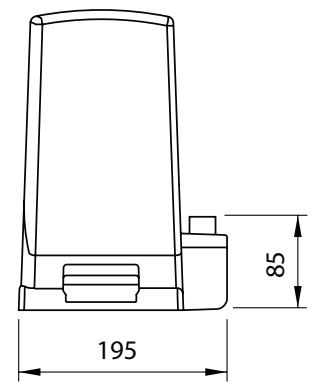
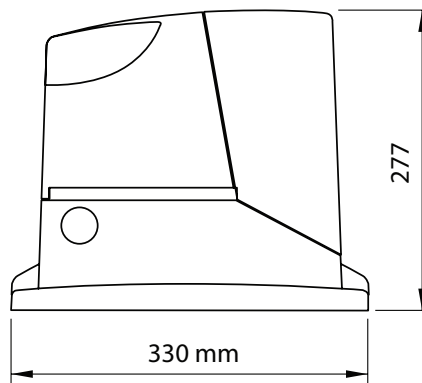

1. MOTOR
2. TRANSMITTER
3. PHOTOCELLS MOUNTED ON POSTS
4. PHOTOCELLS
5. FLASHING LIGHT
6. DIGITAL OR KEY SWITCHES

